

RECOMMENDED PCB LAYOUT

RECOMMENDED PCB THICKNESS: 1.6mm
TOLERANCE: ± 0.05 (TOP VIEW)

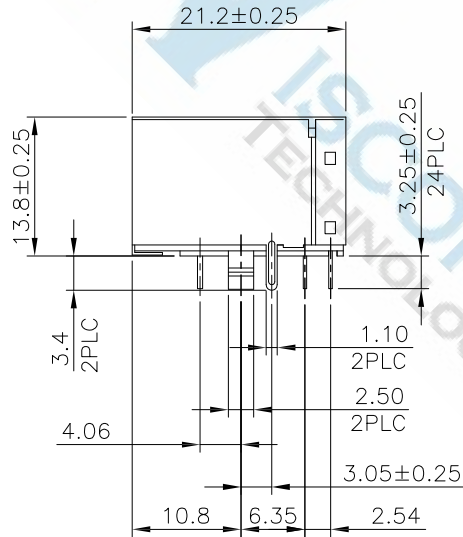

NOTE:

CAVITY CONFIRMS TO FCC RULES AND REGULATIONS PART 68, SUBPART F.

1. MATERIAL:

- HOUSING: PBT WITH GLASS FIBER,,
UL 94V-0, COLOR-BLACK.
- INSERT HOUSING: PBT WITH GLASS FIBER,
UL 94V-0, COLOR-BLACK.
- COVER: PBT WITH GLASS FIBER,
UL 94V-0, COLOR-BLACK.
- CONTACTS: PHOSPHOR BRONZE.
- SHELL: BRASS.

2. FINISH:

- CONTACTS: GOLD PLATED ON CONTACT AREA,
0.0254 μ m [1 μ "] GOLD PLATED ON SOLDER TAIL,
WITH ENTIRE CONTACT UNDERPLATED
1.27 μ m [50 μ "] MIN. NICKEL
- SHELL: 0.508 μ m [20 μ "] MIN. NICKEL PLATED.

DIMENSIONS TOLERANCE	單位(UNITS)	MM	處理(FINISH)	SEE NOTE	審核(CH'K)	Calvin
METRIC						
Up to 5	± 0.2					
Above 5~15	± 0.3					
Above 15~30	± 0.4					
Above 30~50	± 0.5					
Angle	$\pm 0.3^\circ$					

數量(QT'Y)	MM	繪圖(DRAW)	SEE NOTE	審核(CH'K)	Calvin	圖名(NAME)
	N/A				Selena	RJ45 8P8C 1x2 90度 W/LED(4.06) Tab Down DIP BACK PEG 3.05
材料(MT'L)	SEE NOTE	設計(DE'N)	Mike	日期 DATE)	OCT.30.2015	料號(PART NUMBER) WRJ5-88-12-xxRxAA5
						圖號(DRAW NUMBER) T019
						圖檔(FILE NAME .DWG)

WISCONN Technology Co., Ltd
Tel: 02-2790-1979 Fax: 02-2790-1569

比例 (SCALE)	1/1	圖紙 (SIZE)	A4	頁次 (SHEET)	1	版次 (REV.)	A
------------	-----	-----------	----	------------	---	-----------	---