

SECTION A-A

- NOTES:
- MATERIAL:
 - HOUSING: LCP
 - SLIDER: LCP
 - CONTACT: PHOSPHOR BRONZE
 - FITTING NAIL: PHOSPHOR BRONZE

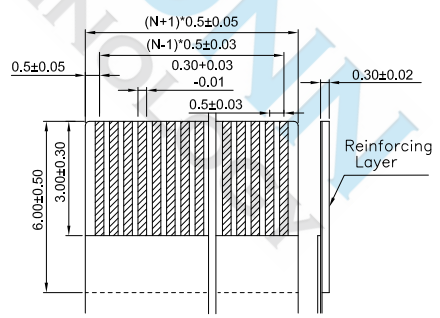

RECOMMENDED FFC/FPC DIM.

PIN数	DIM=A	DIM=B	DIM=C	DIM=D	DIM=E	开模PIN
67P	39.1	38.0	33.0	34.1	4.9	V
60P	35.6	34.5	29.5	30.6		V
59P	35.1	34.0	29.0	30.1		V
58P	34.6	33.5	28.5	29.6		V
57P	34.1	33.0	28.0	29.1	V	
56P	33.6	32.5	27.5	28.6	V	
55P	33.1	32.0	27.0	28.1	V	
54P	32.6	31.5	26.5	27.6	V	
53P	32.1	31.0	26.0	27.1	V	
52P	31.6	30.5	25.5	26.6	V	
51P	31.1	30.0	25.0	26.1	V	
50P	30.6	29.5	24.5	25.6	V	
49P	30.1	29.0	24.0	25.1	V	
48P	29.6	28.5	23.5	24.6	V	
47P	29.1	28.0	23.0	24.1	V	
46P	28.6	27.5	22.5	23.6	V	
45P	28.1	27.0	22.0	23.1	V	
44P	27.6	26.5	21.5	22.6	V	
43P	27.1	26.0	21.0	22.1	V	
42P	26.6	25.5	20.5	21.6	V	
41P	26.1	25.0	20.0	21.1	V	
40P	25.6	24.5	19.5	20.6	V	
39P	25.1	24.0	19.0	20.1	V	
38P	24.6	23.5	18.5	19.6	V	
37P	24.1	23.0	18.0	19.1	V	
36P	23.6	22.5	17.5	18.6	V	
35P	23.1	22.0	17.0	18.1	V	
34P	22.6	21.5	16.5	17.6	V	
33P	22.1	21.0	16.0	17.1	V	
32P	21.6	20.5	15.5	16.6	V	
31P	21.1	20.0	15.0	16.1	V	
30P	20.6	19.5	14.5	15.6	V	
29P	20.1	19.0	14.0	15.1	V	
28P	19.6	18.5	13.5	14.6	V	
27P	19.1	18.0	13.0	14.1	V	
26P	18.6	17.5	12.5	13.6	V	
25P	18.1	17.0	12.0	13.1	V	
24P	17.6	16.5	11.5	12.6	V	
23P	17.1	16.0	11.0	12.1	V	
22P	16.6	15.5	10.5	11.6	V	
21P	16.1	15.0	10.0	11.1	V	
20P	15.6	14.5	9.5	10.6	V	
19P	15.1	14.0	9.0	10.1	4.4	V
18P	14.6	13.5	8.5	9.6		V
17P	14.1	13.0	8.0	9.1		V
16P	13.6	12.5	7.5	8.6		V
15P	13.1	12.0	7.0	8.1	V	
14P	12.6	11.5	6.5	7.6	V	
13P	12.1	11.0	6.0	7.1	V	
12P	11.6	10.5	5.5	6.6	V	
11P	11.1	10.0	5.0	6.1	V	
10P	10.6	9.5	4.5	5.6	V	
9P	10.1	9.0	4.0	5.1	V	
8P	9.6	8.5	3.5	4.6	V	
7P	9.1	8.0	3.0	4.1	V	
6P	8.6	7.5	2.5	3.6	V	
5P	8.1	7.0	2.0	3.1	V	
4P	7.6	6.5	1.5	2.6	V	

DIMENSIONS TOLERANCE METRIC Up to 5 ±0.2 Above 5~15 ±0.3 Above 15~30 ±0.4 Above 30~50 ±0.5 Angle ±0.3°	UNITS	MM	FINISH	SEE NOTE	CH'K	Calvin	DRAW NAME		WISCONN Technology Co., Ltd Tel:+886-2-2790-1979 Fax:+886-2-2790-1569						
	QTY	N/A	DRAW	Johnson	APP'D	Selena	FPC 0.5 CONN H:2.0mm 拉拔式 上接觸								
	MT'L	SEE NOTE	DE'N	Mike	DATE	October . 30. 2019	PART NUMBER	WF05A3-A-xx-P-R							
							DRAW NUMBER	T002	SCALE	1/1	SIZE	A4	SHEET	1	REV.
							FILE NAME .DWG								