

P C B Layout
PCB TOLERANCE: ±0.05

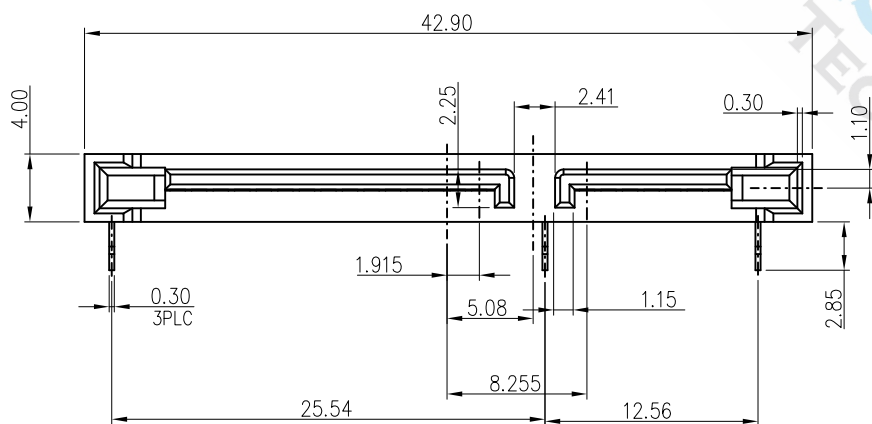

- NOTES:
 1.MATERIAL:
 HOUSING:LCP G/F UL94 V-0
 COLOR:BLACK
 CONTACT:BRASS T=0.25mm
 BOARD LOCK:BRASS T=0.30mm
 2.FINISH:
 CONTACT:GOLD FALSH/TIN PLATING ON CONTACT AREA
 100u" MIN.TIN PLATING ON SOLDERTAILS
 50u" MIN.NICKEL UNDERPLATING OVER ALL
 BOARD LOCK:100u"MIN.TIN PLATION ON SOLDERTAILS
 50u"MIN.TIN NICKEL UNDERPLATING OVER ALL

DIMENSIONS TOLERANCE METRIC	單位(UNITS)	MM	處理(FINISH)	SEE NOTE	審核(CH'K)	Calvin	圖名(NAME)		WISCONN Technology Co., Ltd								
	Up to 5	±0.2					SATA 7+15P 公座 平行三魚叉定位 正向 SMT 90度						Tel:02-2790-1979	Fax:02-2790-1569			
	Above 5~15	±0.3	數量(QT'Y)	N/A	繪圖(DRAW)	Johnson	核准(APP'D)	Selena	料號(PART NUMBER)	WSTAM-22FLBSR-3							
	Above 15~30	±0.4	材料(MT'L)	SEE NOTE	設計(DE'N)	Mike	日期 DATE)	JUN.20.2016	圖號(DRAW NUMBER)	T002	比例(SCALE)	1/1	圖紙(SIZE)	A4	頁次(SHEET)	1	版次(REV.)