

ALL CONTACT
D 0.10

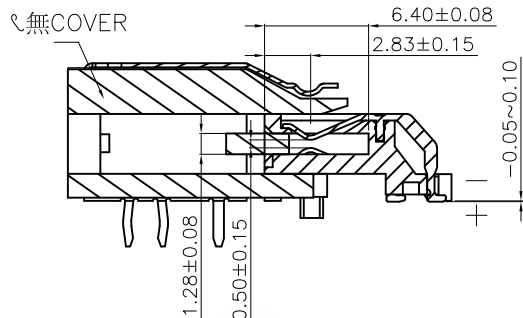

SECTION A-A

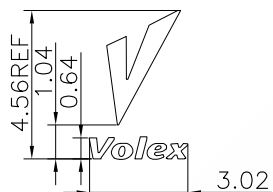

logo深為0.03mm
DETAIL B
SCALE 2:1

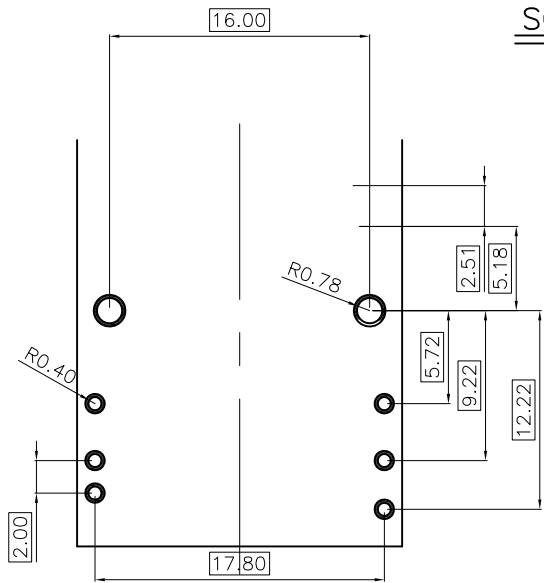
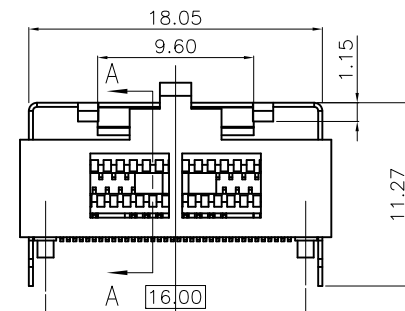
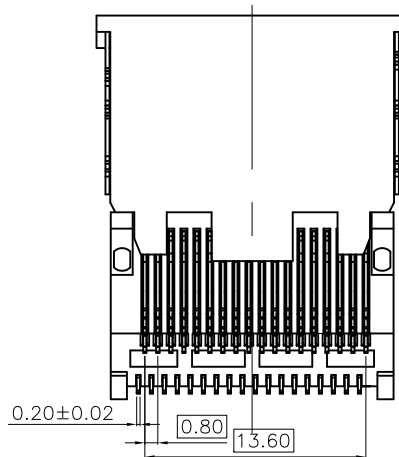

RECOMMENDED PCB LAYOUT

MYLAR
(採用卷包使用)

B
(有LOGO&無LOGO)

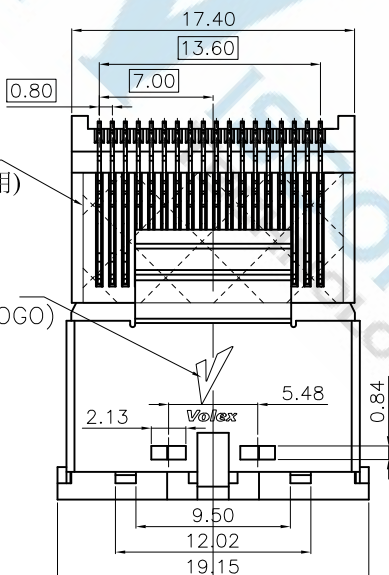

NOTE:

- MATERIAL :
BASE: HIGH THERMOPLASTIC UL94V-0, COLOR : BLACK
TERMINAL: COPPER ALLOY, T= 0.20 mm
SHELL:STEEL,T=0.25mm.
- PLATING:
CONTACT:GOLD PLATED ON THE CONTACT.
TIN PLATED ON THE SOLDER TAIL.
NICKEL UNDERPLATED OVER ALL.
SHELL:NICKEL UNDERPLATED OVER ALL.
- ELECTRONICAL SPECIFICATION:
CURRENT RATING: 0.5 AMPERE PER CONTACT
CONTACT RESISTANCE: 20 MILLIOHMS MAX.
INSULATION RESISTANCE: 1000 MEGOHMS MIN.
DIELECTRIC WITHSTANDING VOLTAGE: 300 VAC.
OPERATING TEMPERATURE: -25°C~+85°C
- THE PRODUCT SHOULD BE GP COMPLIANCE.

| | | | | | | | | | | | | | | | | |
|--|-----------|----------|------------|----------|-----------|-------------|--|--------------------|---|-----|----------|----|-----------|---|----------|---|
| DIMENSIONS TOLERANCE METRIC .0=±0.30 .00=±0.20 .000=±0.10 ANG.=±2° | 單位(UNITS) | MM | 處理(FINISH) | SEE NOTE | 審核(CH'K) | Calvin | 圖名(NAME) MINI SAS 36P SOCKET SMT TYPE 90度 | | WISCONN Technology Co., Ltd Tel:02-2742-1798 Fax:02-2742-1898 | | | | | | | |
| | 數量(QT'Y) | N/A | 繪圖(DRAW) | Johnson | 核准(APP'D) | Selena | 料號(PART NUMBER) | WMIS-36XXLBSR | | | | | | | | |
| | 材料(MT'L) | SEE NOTE | 設計(DE'N) | Mike | 日期 DATE) | OCT.15.2007 | 圖號(DRAW NUMBER) | T006 | 比例(SCALE) | 1/1 | 圖紙(SIZE) | A4 | 頁次(SHEET) | 1 | 版次(REV.) | A |
| | | | | | | | | 圖檔(FILE NAME .DWG) | | | | | | | | |