

RECOMMENDED PCB LAYOUT

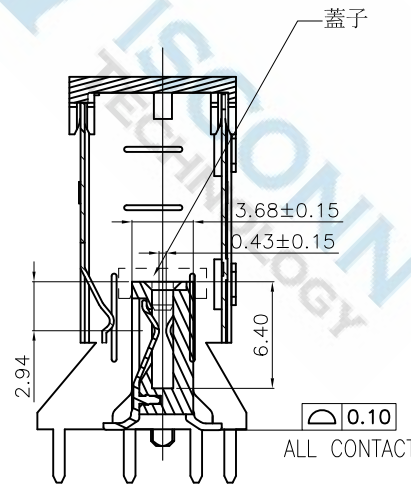
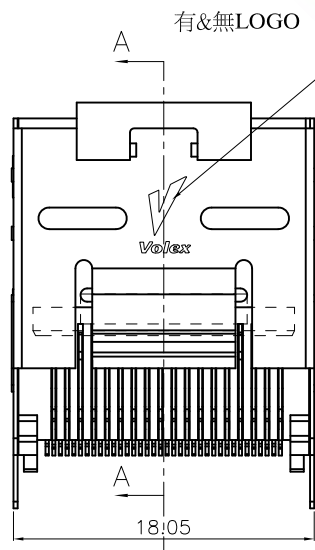
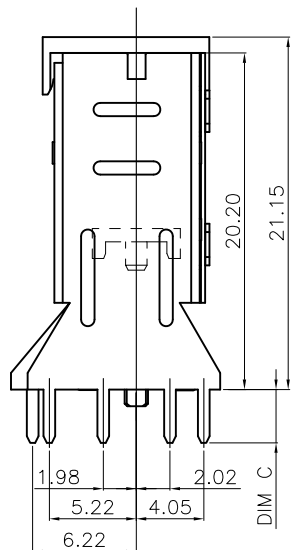
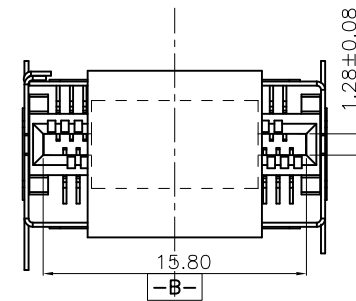
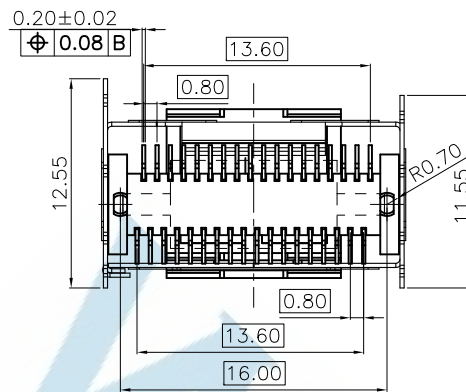

TABLE 1

WMIS-3615LBSV-3.2	15U"	LCP BLACK	3.20	有蓋子	無LOGO
WMIS-3615LBSV-4.2	15U"	LCP BLACK	4.20	有蓋子	有LOGO
WMIS-3630LBSV-4.2	30 U"	LCP BLACK	3.60		
WMIS-3615LBSV-3.6	15U"	LCP BLACK	3.20		
WMIS-3630LBSV-3.6	30 U"	LCP BLACK	3.20		
WMIS-3615LBSV-3.2	15U"	LCP BLACK	3.20		
WMIS-3630LBSV-3.2	30 U"	LCP BLACK			
PART NO.	PLATED	PLASTIC&COLOR	DIM C	NOTE	鐵殼

NOTE:

1.MATERIAL :

BASE&COVER: HIGH THERMOPLASTIC UL94V-0, COLOR : BLACK
 TERMINAL: COPPER ALLOY, T= 0.20 mm
 SHELL: COPPER ALLOY,T= 0.25 mm

2,PLATING:

CONTACT:GOLD PLATED ON THE CONTACT.
 TIN PLATED ON THE SOLDER TAIL.
 NICKEL UNDERPLATED OVER ALL.
 SHELL: NICKEL UNDERPLATED OVER ALL.

3.ELECTRONICAL SPECIFICATION:

CURRENT RATING: 0.5 AMPERE PER CONTACT
 CONTACT RESISTANCE: 20 MILLIOHMS MAX.
 INSULATION RESISTANCE: 1000 MEGOHMS MIN.
 DIELECTRIC WITHSTANDING VOLTAGE: 300 VAC.
 OPERATING TEMPERATURE: -25°C~+85°C

4.MEETS THE REQUIREMENTS OF DIRECTIVE 2002/95/EC OF THE EUROPEAN PARLIAMENT AND OF THE COUNCIL OF 27 JANUARY 2003 ON THE RESTRICTION OF THE USE OF CERTAIN HAZARDOUS SUBSTANCES IN ELECTRICAL AND ELECTRONIC EQUIPMENT(ROHS)

DIMENSIONS TOLERANCE METRIC .0=±0.30 .00=±0.20 .000=±0.10 ANG.=±2°	單位<UNITS>	MM	處理<FINISH>	SEE NOTE	審核<CH'K>	Calvin	圖名<NAME>		WISCONN Technology Co., Ltd Tel:02-2742-1798 Fax:02-2742-1898							
	數量<QT'Y>	N/A	繪圖<DRAW>	Johnson	核准<APP'D>	Selena	MINI SAS 36P SOCKET 180度 SMT TYPE									
	材料<MT'L>	SEE NOTE	設計<DE'N>	Mike	日期<DATE>	OCT.15.2007	料號<PART NUMBER>	WMIS-36XXLBSV-XX								
							圖號<DRAW NUMBER>	T006	圖檔<FILE NAME .DWG>	比例<SCALE>	1/1	圖紙<SIZE>	A4	頁次<SHEET>	1	版次<REV.>