

LAYOUT P.C.B

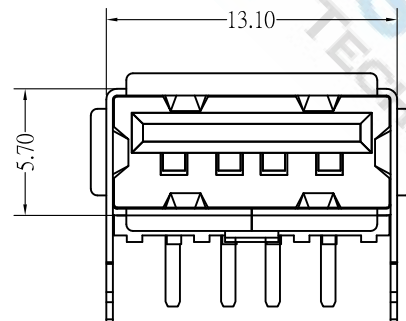
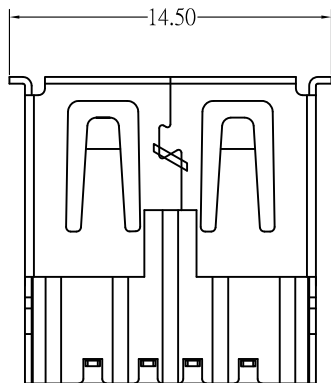
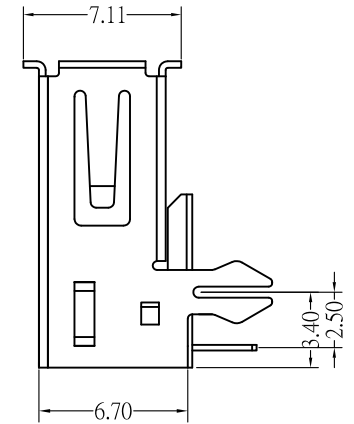
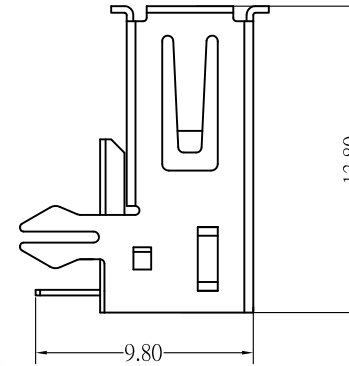
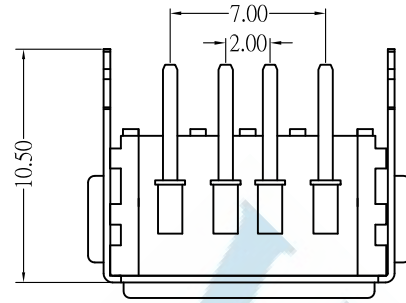

NOTE:

1.MATERIAL:

- a.HOUSING: PBT GLASS FIBRE UL94 V-0
- b.CONTACT: PHOSPHOR BRONZE, PLATED GOLD OVER NICKEL.
- c.SHEEL: SUS , PLATED NICKEL.
- d.TERMINAL: PHOSPHOR BRONZE , PLATED TIN OVER NICKEL.

2.ELECTRIC:

- a.CONTACT RESISTANCE: 30 MILLIOHMS MAX
- b.INSULATION RESISTANCE: 1000 MEGA OHMS MIN
- c.DIELECTNIC VOLTAGE: 500V AC ONE SEC LEVEL
- d.OPERATING TEMPERATURE: -55°C~ 85°C

DIMENSIONS TOLERANCE <b>METRIC</b> .0=±0.30 .00=±0.20 .000=±0.10 ANG.=±2°	單位<UNITS>	MM	處理<FINISH>	SEE NOTE	審校<CH'K>	Calvin	圖名<NAME> USB2.0 A/F R/A DIP 魚叉腳		<b>WISCONN Technology Co., Ltd</b> Tel:02-2742-1798- Fax:02-2742-1898				
	數量<QT'Y>	N/A	繪圖<DRAW>	Johnson	核准<APP'D>	Selena							
	料號<PART NUMBER>	WU2AF-04FPWDRH	圖號<DRAW NUMBER>	T002	圖檔<FILE NAME .DWG>	比例<SCALE>	1/1	圖紙<SIZE>	A4	頁次<SHEET>	1	版次<REV.>	A
	材料<MT'L>	SEE NOTE	設計<DE'N>	Mike	日期<DATE>	OCT.15.2007							