

P.C.B. LAYOUT

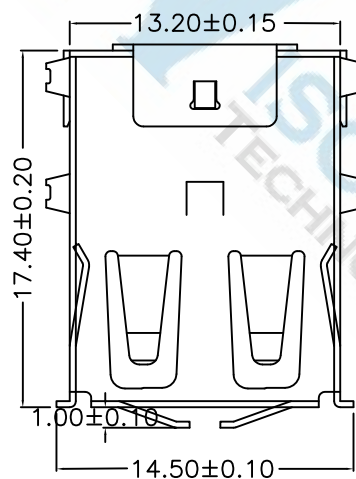
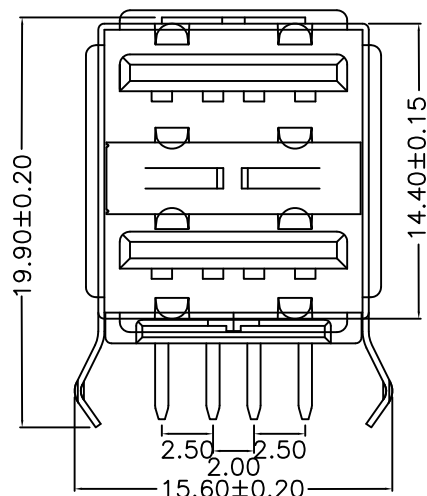

MATERIALS

HOUSING: THERMOPLASTIC (UL 94V-0)
 SHELL: STEEL, NICKEL PLATING
 TERMINAL: COPPER ALLOY, GOLD PLATED ON CONTACT AREA
 TIN PLATING ON SOLDER TAIL

SPECIFICATION

CURRENT RATING: 1 AMP MAX
 DIELECTRIC WITHSTANDING: 500V AC FOR ONE MINUTE
 CONTACT RESISTANCE: 30m OHMS MAX
 INSULATION RESISTANCE: 1000M OHMS MIN AT DC 500V
 OPERATION TEMPERATURE: -25°C~+85°C

DIMENSIONS TOLERANCE METRIC .0=±0.30 .00=±0.20 .000=±0.10 ANG.=±2°	單位(UNITS)	MM	處理(FINISH)	SEE NOTE	審校(CH'K)	Calvin	圖名(NAME)		WISCONN Technology Co., Ltd Tel:02-2742-1798 Fax:02-2742-1898					
	數量(QT'Y)	N/A	繪圖(DRAW)	Johnson	核准(APP'D)	Selena	USB STACKED A/F R/A DIP G/F 有彈片							
	料號(PART NUMBER)	WU2AF-2X1FPWDR-S		圖號(DRAW NUMBER)	T004		比例(SCALE)	1/1	圖紙(SIZE)	A4	頁次(SHEET)	1	版次(REV.)	A
	材料(MT'L)	SEE NOTE	設計(DE'N)	Mike	日期 DATE)	OCT.15.2007	圖檔(FILE NAME .DWG)							