

PCB LAYOUT

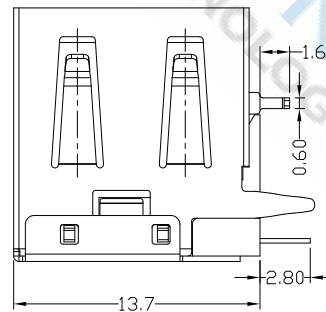
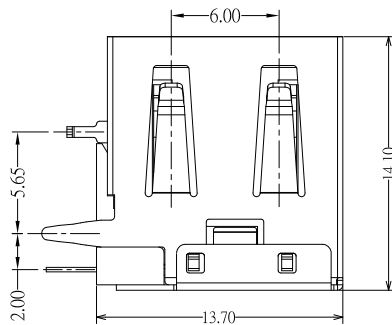
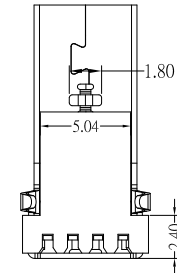
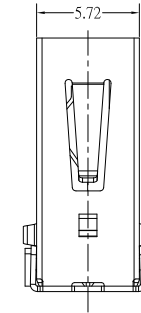

NOTE:

1.MATERIAL:

- a.HOUSING:PBT GLASS FIBRE UL94 V-0 ; BLACK
- b.CONTACT:BRASS
- c.SHEEL: SPCC

1. ELECTRICAL CHARACTERISTECS:

- TEMPERATURE RANGE : -20C TO +85°C
- VOLTAGE CURRENT RATING : 1AMP.30V AC
- INSULATION RESISTANCE : 1,000M OHM MIN
- CONTACT RESISTANCE : 30M OHM MAX
- DIELECTRIC WITHSTANDING VOLTAGE : 500V AC

2. MECHANICAL:

- MATING FORCE: 3.5 KG MAX
- UNMATING FORCE: 0.7 KG MIN.

DIMENSIONS TOLERANCE <b>METRIC</b> .0=±0.30 .00=±0.20 .000=±0.10 ANG.=±2°	單位<UNITS>	MM	處理<FINISH>	SEE NOTE	審核<CH'K>	Calvin	圖名<NAME>		<b>WISCONN Technology Co., Ltd</b> Tel:02-2742-1798 Fax:02-2742-1898								
	數量<QT'Y>	N/A	繪圖<DRAW>	Johnson	核准<APP'D>	Selena	USB A/F 側插短體90度(平口)										
	料號<PART NUMBER>	WU2AF-04FPWDURF-14.0		圖號<DRAW NUMBER>	T002		料號<PART NUMBER>	WU2AF-04FPWDURF-14.0									
	材料<MT'L>	SEE NOTE	設計<DE'N>	Mike	日期<DATE>	OCT.15.2007		圖檔<FILE NAME .DWG>			比例<SCALE>	1/1	圖紙<SIZE>	A4	頁次<SHEET>	1	版次<REV.>